

02

GLOBE VALVE

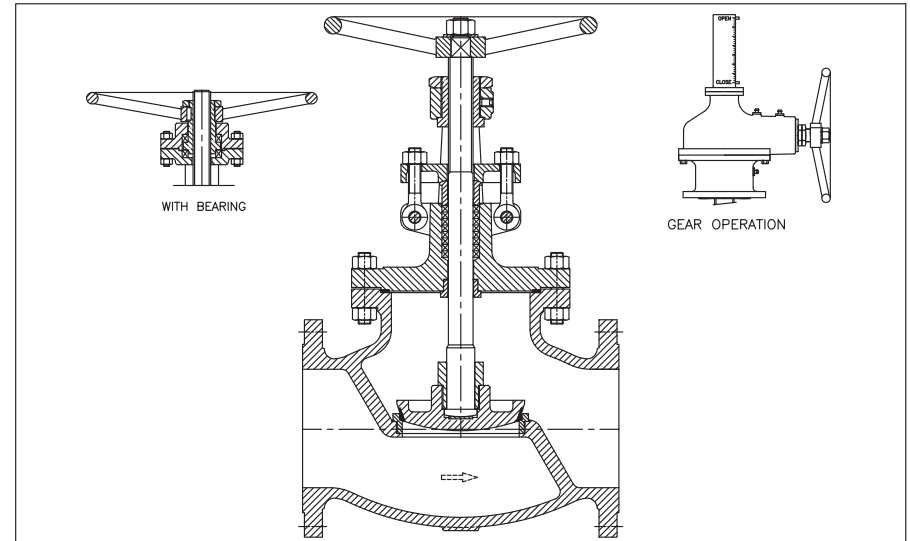

MATERIAL SPECIFICATION

PARTS	MATERIAL		MATERIAL	
BODY	A 216 Gr.WCB	A 217 WC6	A 351 CF8	A 351 CF8M
BONNET	A 216 Gr.WCB	A 217 WC6	A 351 CF8	A 351 CF8M
PLUG	CA15/ 13% Cr. FACING ON WCB	A 217 WC6+ 13%Cr FACING	A 351 CF8	A 351 CF8M
SEAT RING 1	CA15/A 515-70/ 13%Cr FACING	S.S. 304	A 351 CF8	A 351 CF8M
BACK SEAT	T410		INTEGRAL	INTEGRAL
SPINDLE	T410		T304	T316
GLAND BUSH	T410		T304	T316
GLAND FLANGE	CARBON STEEL/WCB		S.S 304	S.S 304
YOKE NUT	ASTM A 439 D2		AL-BRONZE	
PLUG NUT	T410		T304	T304
HAND WHEEL	CARBON STEEL			
HAND WHEEL NUT	A 194 2H		A 194 Gr.8	
STUD & NUT	A 193 B7/A 194 2H	A 193 B16/A 194 Gr. 7	A 193 B8/A 194 Gr.8	
EYE BOLT & NUT	A 193 B7/A 194 2H		A 193 B7/A 194 2H	
CROSS BOLT & NUT	A 193 B7/A 194 2H		A 193 B7/A 194 2H	
GASKET	SPW S.S 304/ 316 WITH GRAFOIL			
GLAND PACKING	GRAPHOIL			
THRUST WASHER	T410 (HARDENED STEEL)		T304	T316
WASHER	STEEL			
GRUB SCREW	STEEL			
LOCK NUT	STEEL			
NAME PLATE	ALUMINIUM/SS			

1 - SEAL WELD 3"NB & ABOVE.
2 - INTEGRAL SEAT FOR AUSTENITIC STEEL VALVES OPTIONAL.
3 - SEAT AND PLUG STELLITING OPTIONAL.

4 - THRUST BEARING, NON-ROTATING STEM WITH YOKE SLEEVE PROVIDED 12"/10"/8"NB & ABOVE SIZES
5 - GUIDED DISC PROVIDED (12"x150#, 300# & 8"x600#).

GLOBE VALVE CLASS 150, 300, 600.
BS 1873/ASME B 16.34

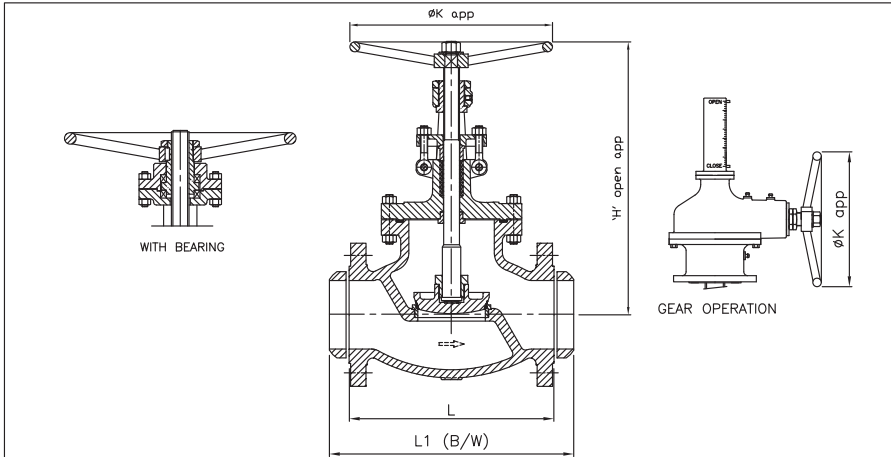

DIMENSION TABLE GBV 150 CLASS

VALVE SIZE in mm	2 50	2.5 65	3 80	4 100	5 125	6 150	8 200	10 250	12 300	14 350	16 400	18 450	20 500	22 550	24 600	26 650	28 700	30 750	32 800	36 900	
L	8.0 203	8.5 216	9.5 241	11.5 292	14.0 356	16.0 406	19.5 495	24.5 622	27.5 698	31.0 787	36.0 914	38.5 978	42.0 1067	51.0 1295	51.0 1295	57.0 1448	60.0 1524	-	-	77.0 1956	
L1	8.0 203	8.5 216	9.5 241	11.5 292	14.0 356	16.0 406	19.5 495	24.5 622	27.5 698	31.0 787	36.0 914	38.5 978	42.0 1067	51.0 1295	51.0 1295	57.0 1448	60.0 1524	-	-	77.0 1956	
H app	12.5 320	13.0 330	15.0 380	18.9 480	20.7 525	22.7 575	25.6 650	30.7 780	36.8 935	46.7 1185	49.2 1250	53.1 1350	55.5 1410	60.0 1525	65.0 1650	-	-	-	-	-	-
ϕK_{app}	200	200	250	300	300	350	450	500	600	700	800	800	850	900	900	-	-	-	-	-	-
Wt. kg app(F/E)	20	30	38	57	75	98	174	282	395	620	790	925	1800	1910	2220	-	-	-	-	-	-

DIMENSION TABLE GBV 300 CLASS

VALVE SIZE in mm	2 50	2.5 65	3 80	4 100	5 125	6 150	8 200	10 250	12 300	14 350	16 400	18 450	20 500	22 550	24 600	26 650	28 700	30 750	32 800	36 900	
L	10.5 267	11.5 292	12.5 318	14.0 356	15.7 400	17.5 444	22.0 559	24.5 622	28.0 711	33.0 838	34.0 864	38.5 978	40.0 1016	44.0 1118	53.0 1346	53.0 1346	59.0 1499	62.7 1594	-	-	82.0 2083
L1	10.5 267	11.5 292	12.5 318	14.0 356	15.7 400	17.5 444	22.0 559	24.5 622	28.0 711	33.0 838	34.0 864	38.5 978	40.0 1016	44.0 1118	53.0 1346	53.0 1346	59.0 1499	62.7 1594	-	-	82.0 2083
H app	14.2 360	16.1 410	17.7 450	20.9 530	23.2 590	25.6 650	29.0 735	32.5 825	37.4 950	45.0 1145	54.0 1370	56.0 1422	58.0 1475	-	-	-	-	-	-	-	-
ϕK_{app}	200	250	300	350	400	450	600	700	750	800	800	850	900	-	-	-	-	-	-	-	-
Wt. kg app(F/E)	30	45	60	95	125	150	235	390	590	965	1115	1400	1800	-	-	-	-	-	-	-	-

DIMENSION TABLE GBV 600 CLASS

VALVE SIZE in mm	2 50	2.5 65	3 80	4 100	5 125	6 150	8 200	10 250	12 300	14 350	16 400	18 450	20 500	22 550	24 600	26 650	28 700	30 750	32 800	36 900	
L	11.5 292	13.0 330	14.0 356	17.0 432	20.0 508	22.0 559	26.0 660	31.0 787	33.0 838	35.0 889	39 991	43 1092	47 1194	-	55.0 1397	57.0 1448	63.0 1600	65.0 1651	-	-	82.0 2083
L1	11.5 292	13.0 330	14.0 356	17.0 432	20.0 508	22.0 559	26.0 660	31.0 787	33.0 838	35.0 889	39 991	43 1092	47 1194	-	55.0 1397	57.0 1448	63.0 1600	65.0 1651	-	-	82.0 2083
H app	16.0 400	16.7 425	19.3 490	25.0 635	27.0 685	29.1 740	38.4 975	42.5 1080	48.4 1230	57 1450	58 1470	65.3 1660	70.5 1790	-	-	-	-	-	-	-	-
ϕK_{app}	250	300	350	400	450	500	600	650	700	700	700	700	750	-	750	750	750	750	-	-	750
Wt. kg app(F/E)	35	40	68	128	185	250	435	825	910	-	-	-	-	-	-	-	-	-	-	-	-

GLOBE VALVE CLASS 900, 1500, 2500.
BS 1873/ASME B 16.34

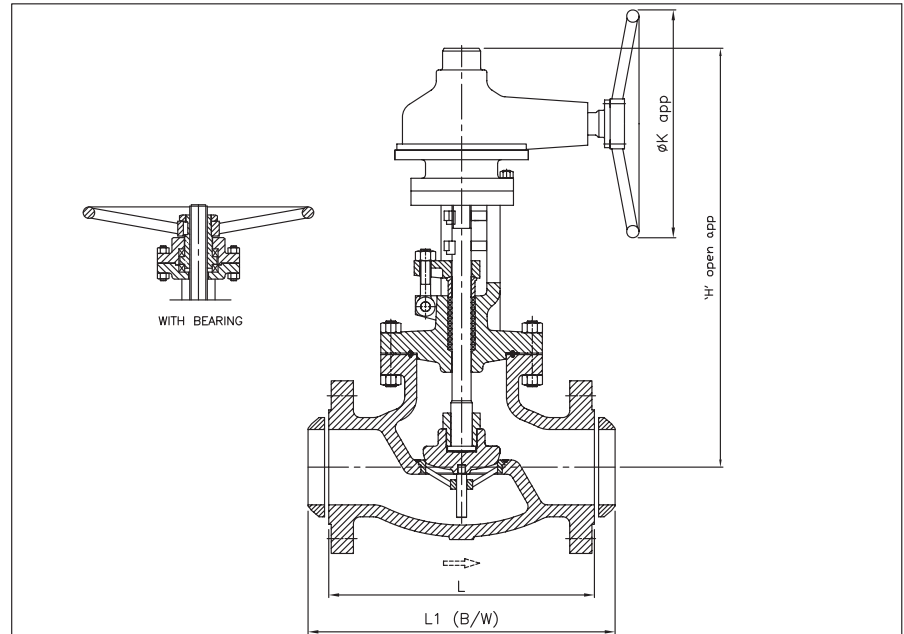

DIMENSION TABLE GBV 900 CLASS

VALVE SIZE in mm	2 50	3 80	4 100	6 150	8 200	10 250	12 300	14 350	16 400	18 450	20 500	24 600
L	14.5 368	15.0 381	18.0 457	24.0 610	29.0 737	33.0 838	37.9 965	40.5 1029	44.4 1130	47.9 1219	52.0 1321	60.9 1549
L1	14.5 368	15.0 381	18.0 457	24.0 610	29.0 737	33.0 838	37.9 965	40.5 1029	44.4 1130	47.9 1219	52.0 1321	60.9 1549
H app	505	605	710	895	980	1150	-	-	-	-	-	-
ϕK_{app}	300	400	500	600	700	735	-	-	-	-	-	-
Wt. kg app(F/E)	85	140	240	450	810	1150	-	-	-	-	-	-

DIMENSION TABLE GBV 1500 CLASS

VALVE SIZE in mm	2 50	3 80	4 100	6 150	8 200	10 250	12 300	16 400
L	14.5 368	18.5 470	21.5 546	27.7 705	32.7 832	39.0 991	44.4 1130	54.4 1384
L1	14.5 368	18.5 470	21.5 546	27.7 705	32.7 832	39.0 991	44.4 1130	54.4 1384
H app	548	750	865	1048	1188	-	1720	-
ϕK_{app}	350	450	500	700	800	-	750	-
Wt. kg app(F/E)	95	155	305	550	900	-	-	-

DIMENSION TABLE GBV 2500 CLASS

VALVE SIZE in mm	2 50	3 80	4 100	6 150	8 200	10 250	12 300	16 400
L	17.7 451	22.7 578	26.4 673	36.0 914	40.2 1022	50.0 1270	55.9 1422	-
L1	17.7 451	22.7 578	26.5 673	36.0 914	40.2 1022	50.0 1270	55.9 1422	-
H app	610	795	975	1080	-	-	-	-
ϕK_{app}	400	500	700	750	-	-	-	-
Wt. kg app(F/E)	115	346	490	910	-	-	-	-

GLOBE VALVE CLASS 900, 1500, 2500.
BS 1873/ASME B 16.34

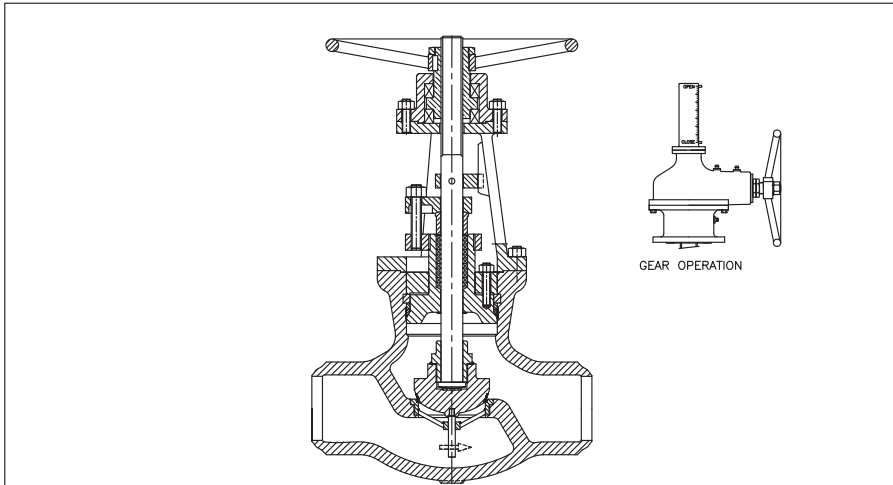

MATERIAL SPECIFICATION

PARTS	MATERIAL		MATERIAL	
BODY	A 216 WCB	A 217 WC6	A 351 CF8	A 351 CF8M
BONNET	A 216 WCB	A 217 WC6	A 351 CF8	A 351 CF8M
YOKE	A 216 WCB	A 217 WC6	A 351 CF8	A 351 CF8M
PLUG	CA15/ 13% Cr. FACING ON WCB+STELLITED	A 217 WC6+STELLITED	A 351 CF8+STELLITED	A 351 CF8M+STELLITED
SEAT RING 1	A 515-70/13%Cr STELLITED	S.S. 304+STELLITED	T304 + STELLITED	T316 + STELLITED
BACK SEAT	INTEGRAL			
SPINDLE	T410		T304	T316
GLAND BUSH	T410		T304	T316
GLAND FLANGE	CARBON STEEL/A 216 WCB		S.S 304	S.S 304
YOKE SLEEVE	ASTM A 439 D2		AL-BRONZE	
CASING COVER	A 216 WCB	A 217 WC6	A 351 CF8	A 351 CF8
BONNET PLATE	A 515-70/A 216 WCB	SS304/A 216 WCB	SS 304	SS 304
GUIDE PLATE	A 515 70/A 216 WCB			
HAND WHEEL	CARBON STEEL			
HAND WHEEL NUT	CARBON STEEL		S.S 304	S.S 304
STUD & NUT	A 193 B7/A 194 2H	A 193 B16/A 194 Gr.7	A 193 B8/A 194 Gr.8	A 193 B8/A 194 Gr.8
GLAND STUD & NUT	A 193 B7/A 194 2H		A 193 B7/A 194 2H	A 193 B7/A 194 2H
CASING STUD & NUT	A 193 B7/A 194 2H			
YOKE STUD & NUT	A 193 B7/A 194 2H			
GLAND PACKING	GRAPHOIL			
SEAL RING	T304		T316	
SPACER RING	ASTM A 515 70	T304	T304	T316
SEGMENTAL RING	ASTM A 515 70	T304	T304	T316
LOCKING BOLT	Gr.B7			
NAME PLATE	ALUMINIUM/SS			
BEARING	STANDARD			

1 - SEAL WELDED

GLOBE VALVE CLASS 900, 1500, 2500.
BS 1873/ASME B 16.34

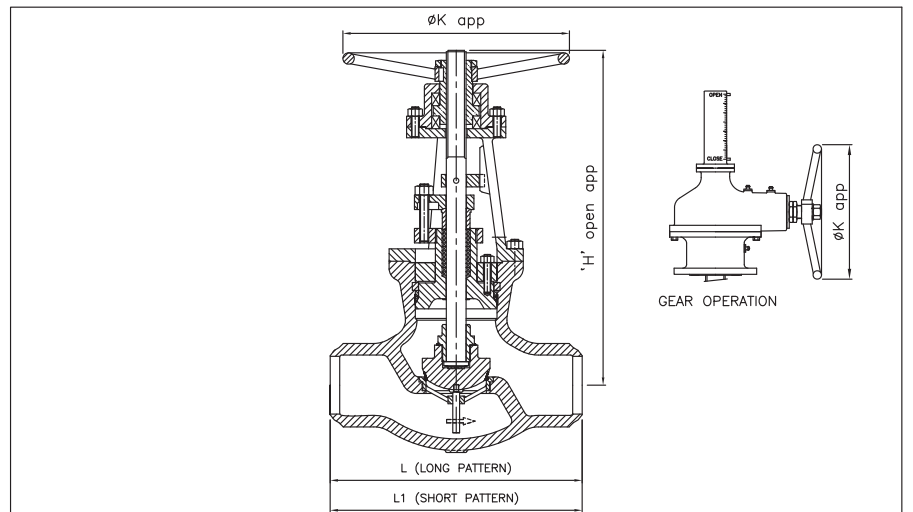

DIMENSION TABLE GBV 900 CLASS

VALVE SIZE	2 in	3 in	4 in	6 in	8 in	10 in	12 in	14 in	16 in	18 in	20 in	24 in
L	14.5 368	15.0 381	18.0 457	24.0 610	29.0 737	33.0 838	38.0 965	40.5 1029	44.5 1130	48.0 1219	52.0 1321	61.0 1549
L1	14.5 368	12.0 305	14.0 356	20.0 508	26.0 660	31.0 787	36.0 914	39.0 991	43.0 1092	-	-	-
H app	460	600	740	860	1040	1120	1475	-	-	-	-	-
ϕK_{app}	300	400	500	600	700	735	650	-	-	-	-	-
Wt. kg app	60	90	170	310	550	770	-	-	-	-	-	-

DIMENSION TABLE GBV 1500 CLASS

VALVE SIZE	2 in	3 in	4 in	6 in	8 in	10 in	12 in	14 in	16 in	18 in	20 in	24 in
L	14.5 368	18.5 470	21.5 546	27.5 705	32.7 832	39.0 991	44.4 1130	49.4 1257	54.4 1384	60.5 1537	65.5 1664	76.4 1943
L1	8.5 216	12.0 305	16.0 406	22.0 559	28.0 711	34.0 864	39.0 991	42.0 1067	47.0 1194	-	-	-
H app	480	785	790	1080	1150	-	-	-	-	-	-	-
ϕK_{app}	350	450	500	700	800	-	-	-	-	-	-	-
Wt. kg app	65	95	235	340	600	-	-	-	-	-	-	-

DIMENSION TABLE GBV 2500 CLASS

VALVE SIZE	2 in	3 in	4 in	6 in	8 in	10 in	12 in	14 in	16 in	18 in	20 in	24 in
L	17.7 451	22.7 578	26.5 673	36.0 914	40.2 1022	50.0 1270	56.0 1422	-	-	-	-	-
L1	11.0 279	14.5 368	18.0 457	24.0 610	30 762	36.0 914	41.0 1041	-	-	-	-	-
H app	610	795	975	1120	1330	1600	1690	-	-	-	-	-
ϕK_{app}	400	500	700	750	750	750	550	-	-	-	-	-
Wt. kg app	80	270	375	610	-	-	-	-	-	-	-	-

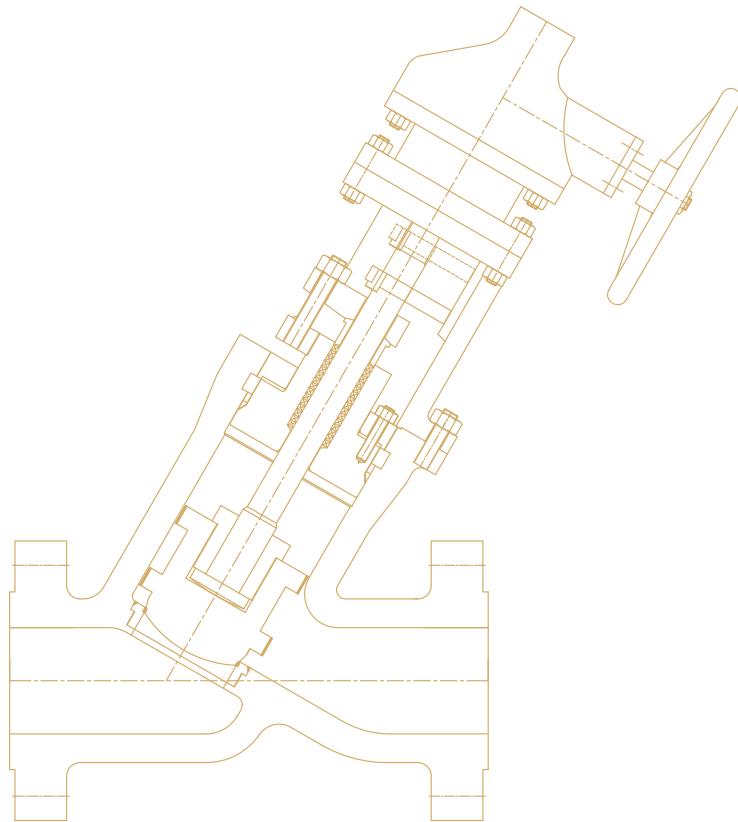

03

Y TYPE GLOBE VALVE

'Y' TYPE GLOBE VALVE CLASS 900, 1500, 2500, 4500.
BS 1873/ASME B 16.34

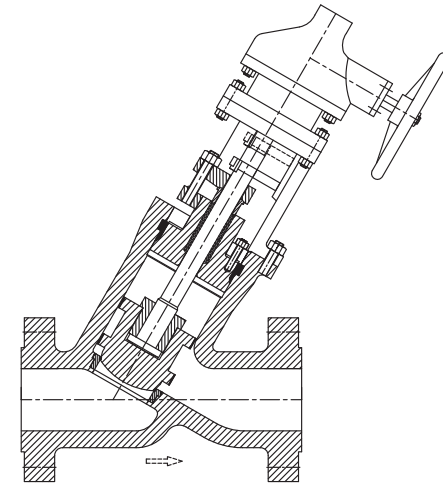

MATERIAL SPECIFICATION

PARTS	MATERIAL			
BODY	A 216 WCB	A 217 WC6	A 351 CF8	A 351 CF8M
BONNET	A 216 WCB	A 217 WC6	A 351 CF8	A 351 CF8M
YOKE	A 216 WCB	A 217 WC6	A 351 CF8	A 351 CF8M
PLUG	CA15/13%Cr. FACING ON WCB+STELLITED	A 217 WC6+STELLITED	A 351 CF8+STELLITED	A 351 CF8M+STELLITED
SEAT RING	A 105/13%Cr. +STELLITED	S.S 304+STELLITED	SS 304+STELLITED	SS 316+STELLITED
BACK SEAT	T410	T410	INTEGRAL	INTEGRAL
SPINDLE	T410	T410	T304	T316
GLAND BUSH	T410	T410	T304	T316
GLAND FLANGE	A 216 WCB	A 217 WC6	A 351 CF8	A 351 CF8M
YOKE SLEEVE	A 439 Gr.D2		AL-BRONZE	
PLUG NUT	T410		T304	T316
BONNET PLATE	A 515-70		S.S 304	
GLAND PLATE	A 515-70		S.S 304	
GUIDE PLATE	A 515-70		S.S 304	
HAND WHEEL	CARBON STEEL		CARBON STEEL	
STUD & NUT	A 193 B7/A 194 2H	A 193 B16/A 194 Gr. 7	A 193 B8/A 194 Gr.8	
GLAND STUD & NUT	A 193 B7/A 194 2H		A 193 B7/A 194 2H	
YOKE STUD & NUT	A 193 B7/A 194 2H		A 193 B7/A 194 2H	
MOUNTING STUD & NUT	A 193 B7/A 194 2H		A 193 B7/A 194 2H	
GLAND PACKING	GRAFOIL			
SEAL RING	T304		T304	T316
SPACER RING	A 515-70		SS 304	
SEGMENTAL RING	A 515-70		SS 304	
KEY	C40			
NAME PLATE	ALUMINIUM/S.S.			
GEAR BOX. ASSLY.	NITON MAKE			

'Y' TYPE GLOBE VALVE CLASS 150, 300, 600.

BS 1873

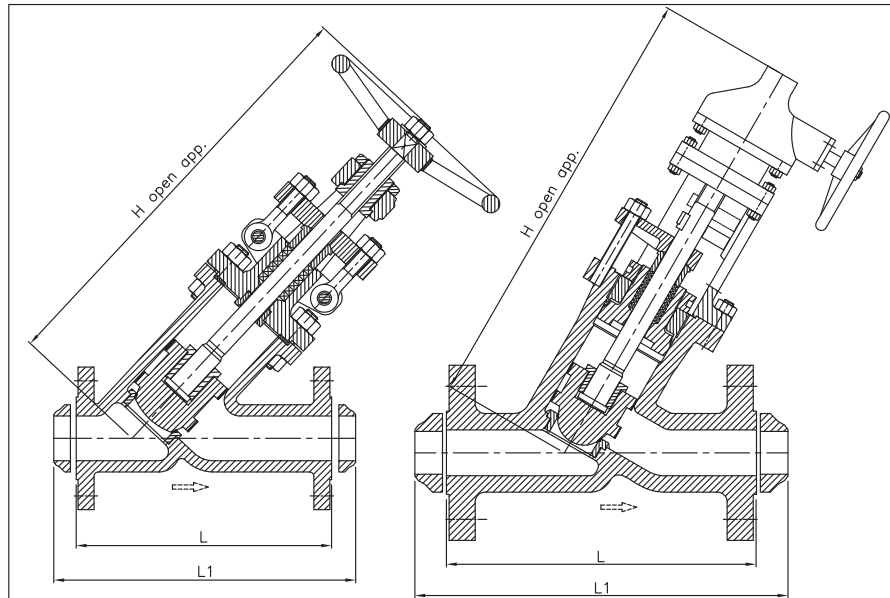

DIMENSION TABLE 150 CLASS

VALVE SIZE in mm	2 50	3 80	4 100	6 150	8 200	10 250	12 300	14 350	16 400	18 450	20 500	22 550	24 600
L	9.0 229	12.5 318	14.4 368	18.5 470	23.5 597	26.5 673	30.5 775	-	-	-	-	-	-
L1	9.0 229	12.5 318	14.4 368	18.5 470	23.5 597	26.7 673	30.5 775	-	-	-	-	-	-
H app	455	495	530	575	620	665	-	-	-	-	-	-	-
Wt. kg app(F/E)	-	-	-	-	-	-	-	-	-	-	-	-	-

DIMENSION TABLE 300 CLASS

VALVE SIZE in mm	2 50	3 80	4 100	6 150	8 200	10 250	12 300	14 350	16 400	18 450	20 500	22 550	24 600
L	10.5 267	12.5 318	14.0 356	17.5 444	22.0 559	24.5 622	-	-	-	-	-	-	-
L1	10.5 267	12.5 318	14.0 356	17.5 444	22.0 559	24.5 622	-	-	-	-	-	-	-
H app	410	480	520	590	650	710	-	-	-	-	-	-	-
Wt. kg app(F/E)	-	-	-	-	-	-	-	-	-	-	-	-	-

DIMENSION TABLE 600 CLASS

VALVE SIZE in mm	2 50	3 80	4 100	6 150	8 200	10 250	12 300	14 350	16 400	18 450	20 500	22 550	24 600
L	11.5 292	14.0 356	17.0 432	22.0 559	26.0 660	31.0 787	-	-	-	-	-	-	-
L1	11.5 292	14.0 356	17.0 432	22.0 559	26.0 660	31.0 787	-	-	-	-	-	-	-
H app	430	510	545	635	680	740	-	-	-	-	-	-	-
Wt. kg app(F/E)	-	-	-	-	-	-	-	-	-	-	-	-	-

'Y' TYPE GLOBE VALVE CLASS 900, 1500, 2500, 4500.

BS 1873/ASME B 16.34

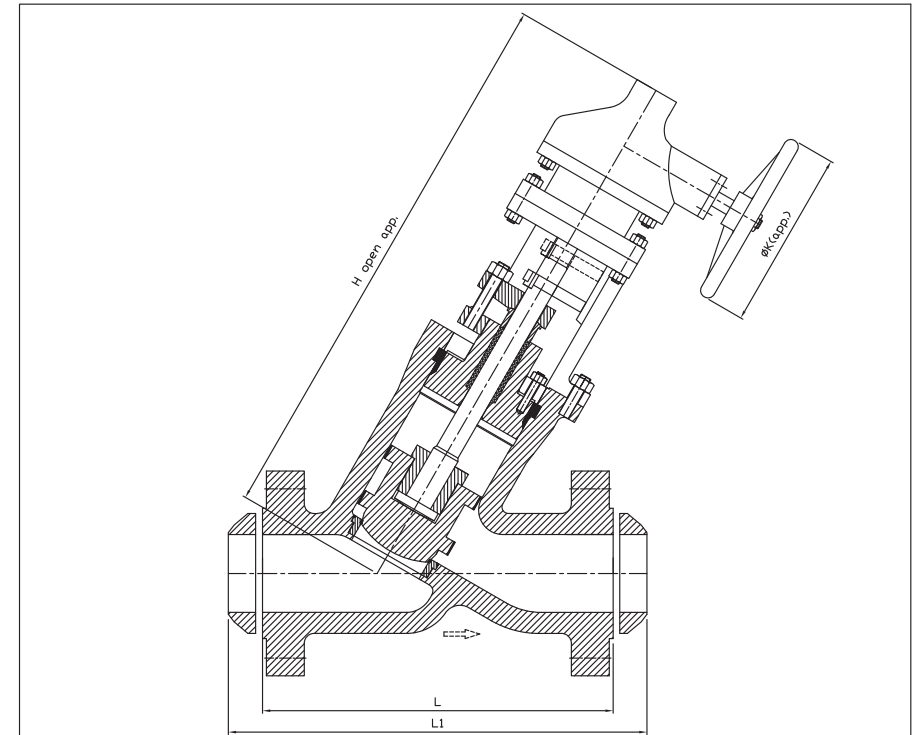

DIMENSION TABLE 900 CLASS

VALVE SIZE in mm	2 50	3 80	4 100	6 150	8 200	10 250	12 300
L	14.4 368	15.0 381	17.9 457	24.0 610	29.0 737	32.9 838	-
L1	-	-	-	-	-	-	-
H app	540	590	650	750	1175	1380	-
øK app	350	400	500	600	700	750	-
Wt. kg app(F/E)	-	-	-	-	-	-	-

DIMENSION TABLE 1500 CLASS

VALVE SIZE in mm	2 50	3 80	4 100	6 150	8 200	10 250	12 300
L	14.4 368	18.5 470	21.4 546	27.7 705	32.7 832	39.0 991	-
L1	14.4 368	18.5 470	21.4 546	27.7 705	32.7 832	39.0 991	-
H app	540	590	675	775	1210	1415	-
øK app	350	450	550	650	750	750	-
Wt. kg app(F/E)	-	-	-	-	-	-	-

DIMENSION TABLE 2500 CLASS

VALVE SIZE in mm	2 50	3 80	4 100	6 150	8 200	10 250	12 300
L	17.7 451	22.7 578	26.4 673	35.9 914	40.2 1022	-	-
L1	-	-	-	-	-	-	-
H app	580	770	960	1000	1150	1390	-
øK app	-	-	-	-	-	-	-
Wt. kg app(F/E)	-	-	-	-	-	-	-

DIMENSION TABLE 4500 CLASS

VALVE SIZE in mm	2 50	3 80	4 100	6 150	8 200	10 250	12 300
L	-	-	-	-	-	-	-
L1	-	-	-	-	-	-	-
H app	-	-	-	-	-	-	-
øK app	-	-	-	-	-	-	-
Wt. kg app(F/E)	-	-	-	-	-	-	-